

AXMINSTER

WORKSHOP

Code 107679

Original Instructions

AW150BDS

Belt & Disc Sander



AT: 09/02/2022
BOOK VERSION: 03

INDEX OF CONTENTS

EU Declaration of Conformity	02
What's Included	03
Introduction	04
Packaging	04
General Instructions for 230V Machine	04
Specific Safety Precautions for Sanding Machines	05
Specification	05
Assembly	06-07
Set up & Adjustment	07-08-09
Illustration and Parts Description	10-11-12
Operating Instructions	13
Changing the Abrasive Belt/Disc	13-14-15-16
Maintenance	17-18
Trouble Shooting	19
Exploded Diagrams/Lists	20-21-22
Wiring Diagram	23

EU DECLARATION OF CONFORMITY

<p>Cert No: MM491E</p> <p>Axminster Tool Centre Ltd Axminster Devon EX13 5PH UK axminstertools.com</p> <p>declares that the machinery described:-</p> <table border="1"> <tr> <td>Type</td> <td>Belt & Disc Sander</td> </tr> <tr> <td>Model</td> <td>AW150DBS</td> </tr> </table> <p>Signed </p> <p>Andrew Parkhouse Operations Director</p> <p>Date: 28/04/2018</p>	Type	Belt & Disc Sander	Model	AW150DBS	<p>EU Declaration of Conformity</p> <p>This machine complies with the following directives:</p> <table border="0"> <tr> <td>2006/42/EC</td> <td>EN 55014-1:2017+A11</td> </tr> <tr> <td>2014/30/EU</td> <td>EN 55014-2:2015</td> </tr> <tr> <td>EN ISO 12100:2010</td> <td>IEC 61000-3-2:2019</td> </tr> <tr> <td>EN 62841-1:2015</td> <td>EN 61000-3-3:2013+A1</td> </tr> <tr> <td>AfPS GS 2014: 01</td> <td></td> </tr> </table> <p>and conforms to the machinery example for which the EC Type-Examination Certificate No AM50401624, AE50495456 has been issued by Wendeng Allwin Motors Manufacturing Co., Ltd. at: No. 15 Sichan Road Wendeng, Shandong 264400 China (Mainland)</p> <p>and complies with the relevant essential health and safety requirements.</p>	2006/42/EC	EN 55014-1:2017+A11	2014/30/EU	EN 55014-2:2015	EN ISO 12100:2010	IEC 61000-3-2:2019	EN 62841-1:2015	EN 61000-3-3:2013+A1	AfPS GS 2014: 01	
Type	Belt & Disc Sander														
Model	AW150DBS														
2006/42/EC	EN 55014-1:2017+A11														
2014/30/EU	EN 55014-2:2015														
EN ISO 12100:2010	IEC 61000-3-2:2019														
EN 62841-1:2015	EN 61000-3-3:2013+A1														
AfPS GS 2014: 01															

The symbols below advise the correct safety procedures when using this machine.



Fully read manual and safety instructions before use



Ear protection should be worn



Eye protection should be worn



Dust mask should be worn



HAZARD
Motor gets hot

WHAT'S INCLUDED

Quantity	Item	Part	Model Number
1	Belt & Disc Sander	A	AW150BDS
1	Worktable	B	
1	Hex Key	C	
1	Mitre Fence	D	
1	Linisher Guard	E	
1	Instruction Manual		



NOTE: Please read the Instruction Manual prior to using your new machine; as well as the operating procedures for your new machine, there are numerous hints and tips to help you to use the machine safely and to maintain its efficiency and prolong its life.

Keep this instruction manual readily accessible for any others who may also be required to use the machine.

INTRODUCTION

A neatly designed belt and disc sander.

The worktable on the belt and disc sander is a decent size and used on both functions. The table is easy to transfer from one function to the other. The table pivots from 0° to 45° and incorporates a mitre fence running in a slot for bevel and compound angle sanding. The sanding finisher also moves from vertical to horizontal with just two

hexagon socket bolts to loosen with a key, suiting the task in hand. The belt has close fitting guarding which helps this machine achieve a high level of efficient dust extraction. When connected to a simple vacuum extractor almost total dust extraction is achievable. The chassis is heavily constructed in a single iron casting to support the tables and belt arm, and has locating holes for securing this sander to a workbench if you so wish.

PACKAGING



HAVING UNPACKED YOUR SANDER, PLEASE DISPOSE OF THE PACKAGING PROPERLY. THE PACKAGING IS BIODEGRADABLE.

Having opened the box, remove the top packaging and lift the machine out and place upon a clear flat surface, taking care not to trap or pinch the power cable under the chassis. Remove the remaining items from the box and place safely aside.

GENERAL INSTRUCTIONS FOR 230V MACHINES

The following will enable you to observe good working practices, keep yourself and fellow workers safe and maintain your tools and equipment in good working order.



WARNING!! KEEP TOOLS AND EQUIPMENT OUT OF REACH OF YOUNG CHILDREN



KEEP WORK AREA AS UNCLUTTERED AS IS PRACTICAL. UNDER NO CIRCUMSTANCES SHOULD CHILDREN BE ALLOWED IN WORK AREAS.

Mains Powered Tools

- Tools are supplied with an attached 13 Amp 3 pin plug, fitted with 10 amp fuse.
- Inspect the cable and plug to ensure that neither are damaged. Repair if necessary by a suitably qualified person.
- Do not use when or where it is liable to get wet.

Workplace

- Do not use 230V a.c. powered tools anywhere within a site area that is flooded.
- Keep machine clean.

- Leave machine unplugged until work is about to commence.
- Always disconnect by pulling on the plug body and not the cable.
- Carry out a final check e.g. check the cutting tool is securely tightened in the machine and the correct speed and function set.
- Ensure you are comfortable before you start work, balanced, not reaching etc.
- Wear appropriate safety clothing, goggles, gloves, masks etc. Wear ear defenders at all times.
- If you have long hair wear a hair net or helmet to prevent it being caught up in the rotating parts of the machine.
- Consideration should be given to the removal of rings and wristwatches.
- Consideration should also be given to non-slip footwear etc.
- If another person is to use the machine, ensure they are suitably qualified to use it.
- Do not use the machine if you are tired or distracted.
- Do not use this machine within the designated safety areas of flammable liquid stores or in areas where there may be volatile gases.
- Check cutters are correct type and size, are undamaged and are kept clean and sharp, this will maintain their operating performance and lessen the loading on the machine.
- **OBSERVE....** make sure you know what is happening around you and **USE YOUR COMMON SENSE.**

SPECIFIC SAFETY PRECAUTIONS FOR SANDING MACHINES

DO NOT sand very small pieces of work with bare hands; try to construct some form of holder.

Make sure you are comfortable before you start work, balanced, not reaching etc. If the work you are carrying out is liable to generate excessive grit or dust or chips wear the appropriate safety clothing, goggles, masks etc. If the work operation appears to be excessively noisy wear ear-defenders. If you wear your hair in a long style wearing a cap, safety helmet, hairnet, even a sweatband, will minimise the possibility of your hair being caught up in the rotating parts of the machine. Likewise, consideration should be given to the removal of rings and wristwatches if these are liable to be a 'snag' hazard.

DO NOT work with cutting/abrasive tools of any description if you are tired, your attention is wandering or you are being subjected to distraction.

DO NOT use the machine within the designated safety areas of flammable liquid stores or in areas where there may be volatile gases.

Check that sanding surfaces are still sufficiently abrasive to carry out the work you intend. Sanding belt cleaning sticks are an efficient method of prolonging the life of the belts and discs and will also maintain their operating performance.

Check that the belts or discs are undamaged; torn edges can pick up on the work piece and will cause the medium to tear, often very rapidly with accompanying sharp flapping edges.

Always offer the work piece to the belt/disc so that the motion carries the work against the restraining surface i.e. the work stop or the table (use the left hand side of the disc).

DO NOT press too heavily against the sanding surface, all this will do is slow the sander down. Remember, sanders work by removing small particles of material quickly and heavy pressure works adversely to the cutting process. Further, it will accelerate the rate of 'clogging' of the abrasive surfaces, rendering the machine less efficient.

If you are attempting to sand inside curves (over the 'tracking drum') do not press at all, other than to keep the work piece in contact with the surface, any pressure could upset the tracking geometry. As there is no cushioning effect to the belt passing around the drum, expect an added vibration and compensate for it.

Sanding of certain types of timber may make the fitting of dust extraction mandatory in order to comply with the directives of the HSE. However, even if it is not mandatory, it is strongly recommended that you consider fitting dust extraction. It will certainly reduce the level of dust and grit, and as it helps to remove the waste quicker will certainly prolong the longevity of the abrasive.

Above all, OBSERVE.... make sure you know what is happening around you, and **USE YOUR COMMON SENSE.**

SPECIFICATION

Code	107679
Model	AW150BDS
Rating	Workshop
Power	230V 50Hz 370W 1Ph
Duty Cycle	S1 370W
Belt Size	100 x 914 mm
Disc Size	150 mm
Table Size	216 x 146 mm
Disc Table Tilt	0° - 45°
Dust Extraction Outlet	63 mm
Overall L x W x H	470 x 370 x 295 mm
	500 x 250 x 650 mm
Weight	21kg

ASSEMBLY

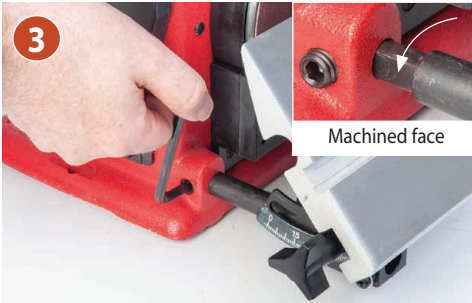
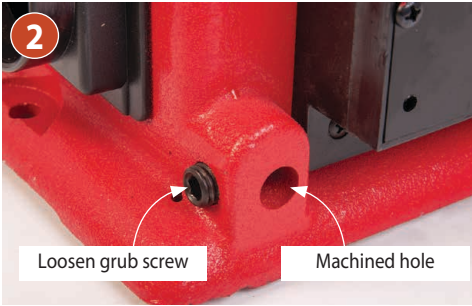
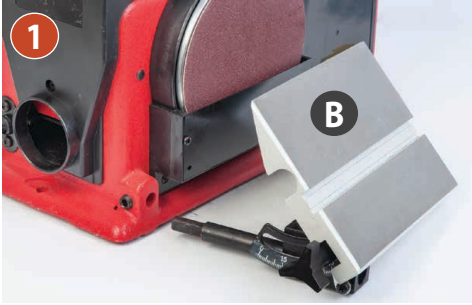

Slide the table (B) mounting bar into the machined hole and tighten the grub screw using the supplied Hex key.



Using a square adjust the table until its perpendicular with the sanding disc.

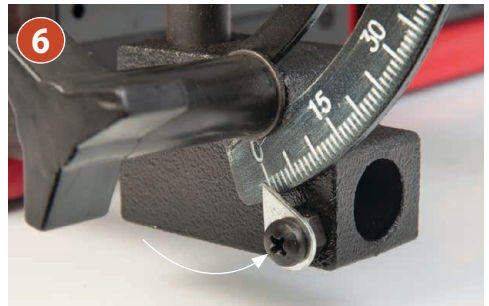

Reset the pointer to 'ZERO' by loosening clamping screw.

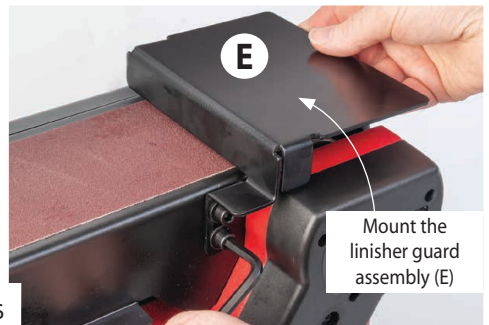

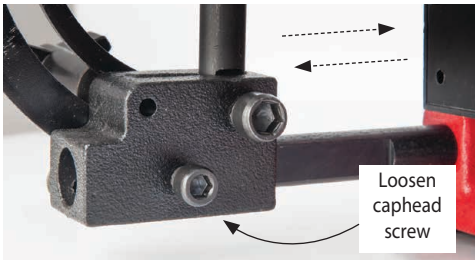
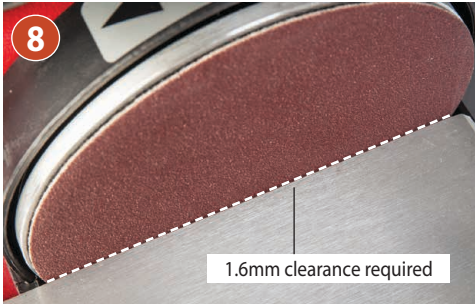

The gap between the table and the disc should be set to a maximum of 1.6mm to clear the debris and to ensure sufficient support for the timber.

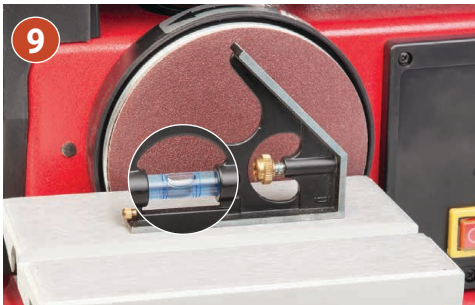

Check the table is level and adjust by loosening the caphead screw as shown above.

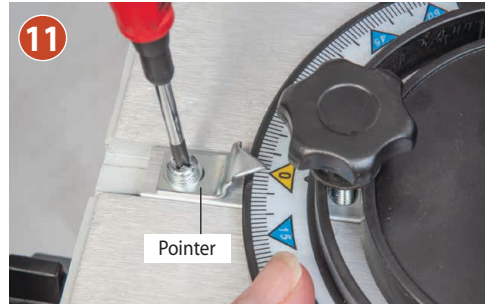

Slide the mitre fence (D) onto the table, place a square against the fence/disc and adjust until square. Reset the pointer to 'Zero'.



Setting Up the Linisher

The linisher can be raised to the vertical position to utilise the worktable (B). See instruction below for setting up the linisher.



Loosen the two clamping Hex screws holding the linisher in the horizontal position and raise the linisher to the vertical position.

SETUP & ADJUSTMENT



Tighten the two Hex screws to secure the linisher in position, see step 3.

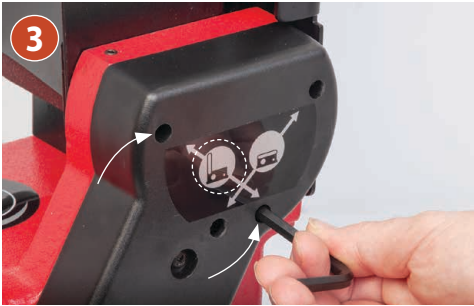

Remove the linisher guard (E) clamping Hex screws and place the guard safely to one side. Replace the two Hex screws/washers to the side of the linisher.

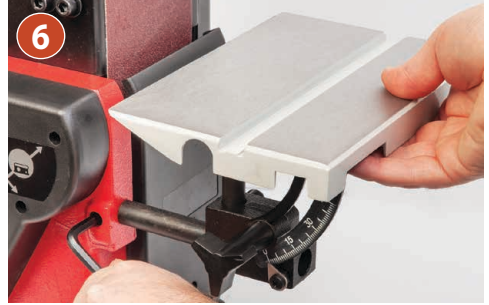

Transfer the work table (B) from the disc function mounting to the linisher's mounting hole and secure in position. Setup the table as described earlier, see the following steps.

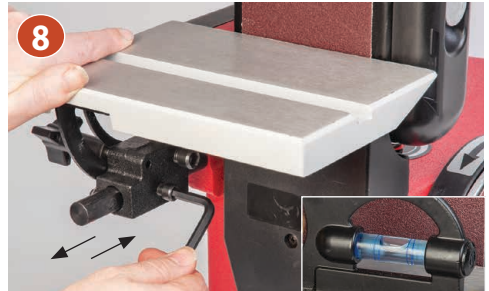

Tracking the Linisher Belt

The tracking control works as follows:-

Using your hand, roll the belt towards the drive drum, check that the belt stays in the middle of the table, if not, adjust the track control slightly, and move the belt again, continue until the belt runs down the centre of the linisher's table



DO NOT make large adjustments, and remember the belt may take time to react to your alteration. Little by little is a good maxim to observe when carrying out tracking operations.



Turn the tracking wheel towards you to manoeuvre the belt to the left.



Turn the tracking wheel away from you to manoeuvre the belt to the right.

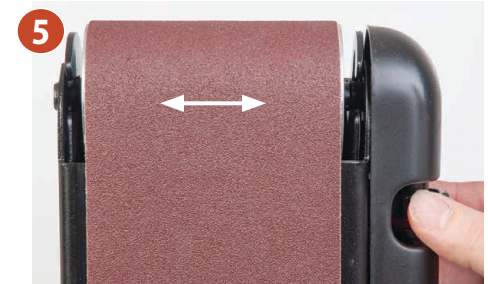

Belt tracking down the centre of the linisher



ILLUSTRATION AND PARTS DESCRIPTION

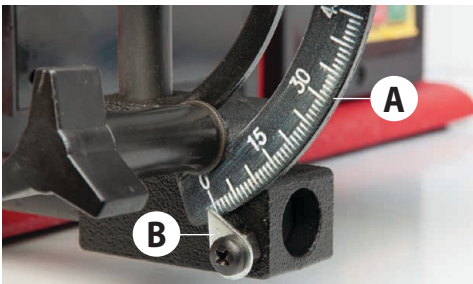

Worktable tilt scale (A) and pointer (B)

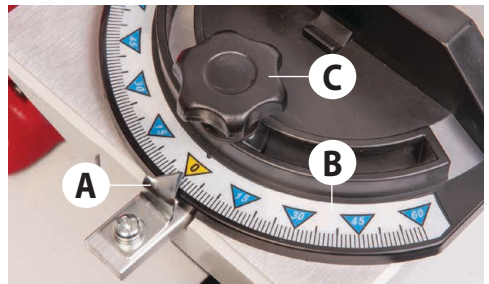

Mitre fence pointer (A), scale (B) and clamping knob (C)

ILLUSTRATION AND PARTS DESCRIPTION



Linisher's stop/ levelling bolt

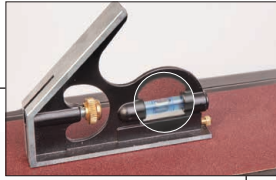

Work bench mounting hole

Drive belt cover



Mitre fence and Hex key storage holders

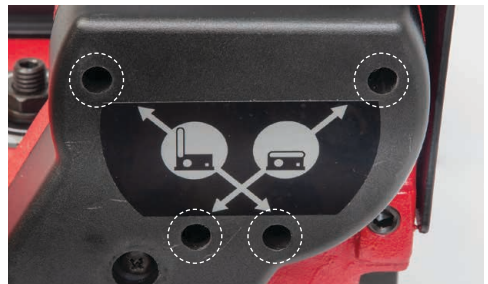

Clamping Hex bolts, access holes for linisher assembly

ILLUSTRATION AND PARTS DESCRIPTION



NVR ON/OFF control switch



63mm dust extraction outlet



Drive belt tensioning grub screw and locking nut



Linisher guard/Workstop, can be used as a work support when the linisher is in the vertical position

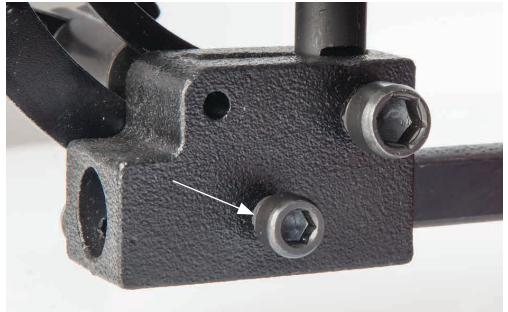

Worktable adjusting Hex bolt

Three function positions



Linisher function with worktable



Linisher function, utilising the linisher's guard as a work support



Disc function (A) set at 90° degrees
Disc function (B) set at 45° degrees

OPERATING INSTRUCTIONS/ CHANGING THE ABRASIVE BELT/DISC



MAKE SURE THE SANDER IS ON A FLAT LEVEL SURFACE.



NOTE: GO ROUND AND MAKE SURE EVERYTHING IS SECURE, FASTENED DOWN, THAT ALL TOOLS ARE CLEARED AWAY FROM THE WORK AREA!



WARNING!! KEEP TOOLS AND EQUIPMENT OUT OF REACH OF YOUNG CHILDREN



CONNECT A DUST EXTRACTION MACHINE TO THE SANDER.



ALWAYS WEAR EAR DEFENDERS, EYE PROTECTION AND DUST MASK.



CONNECT THE SANDER TO THE MAINS SUPPLY!

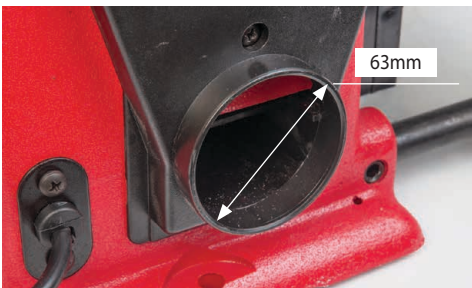

Connect your extraction hose to the sander's outlet.

Give the machine a 'quick' burst check (i.e. quick ON-OFF) to ensure everything is O.K. If everything is satisfactory, the Sander is ready for use.

Sanding Disc



DISCONNECT THE SANDER FROM THE MAINS SUPPLY BEFORE CONTINUING!



Remove the worktable (B) and place safely aside.



Remove the two screws holding the extraction plate and place to one side.

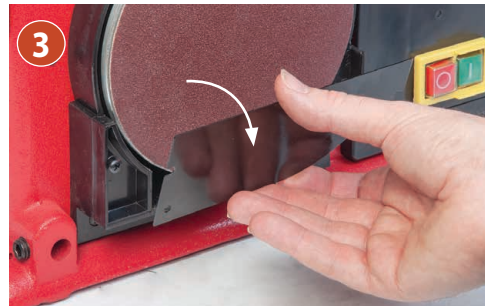

WEAR A DUST MASK & EYE PROTECTION WHEN CHANGING THE DISC!

CHANGING THE ABRASIVE BELT/DISC



The abrasive disc is attached to the sander's face by Velcro, a strip of fabric that clings when pressed together. Simply peel off the old abrasive disc. Clean the surface of the disc.



Line up the new abrasive disc with the face of sanding disc and using a piece of cloth in your hand or wear a glove, to firmly press the abrasive to the disc plate, the application will be reinforced by a gentle sanding action across the face when you first use the new sanding disc. Re-assemble the sander.

Linisher Belt



DISCONNECT THE SANDER FROM THE MAINS SUPPLY BEFORE CONTINUING!



Loosen the two clamping Hex screws holding the linisher and raise to the vertical position. Tighten the Hex screws.

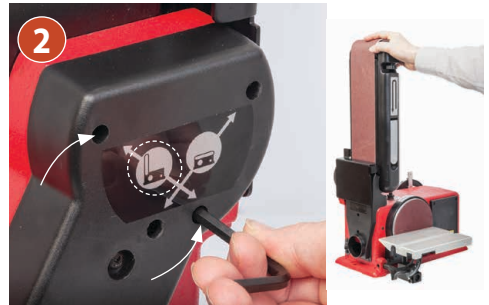

Remove the worktable (B) if installed for easy access and place to one side.



CONNECT THE SANDER TO THE MAINS SUPPLY AND CONTINUE WITH OPERATION.

CHANGING THE ABRASIVE BELT/DISC



Loosen the two screws holding the rear guard.

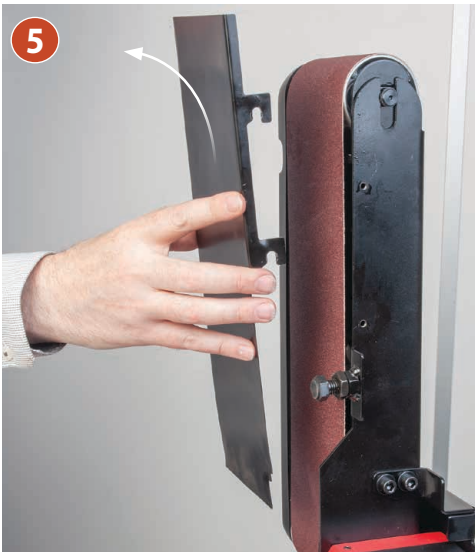

Lift and remove the rear guard, place to one side.



Release the belt tension by lifting up the tensioning lever.



WEAR A DUST MASK & EYE PROTECTION WHEN CHANGING THE BELT!

Remove the liner belt. Inspect the new belt, ensure that there are no tears or rips especially along the edges, check the direction arrows on the inner surface of the belt and fit accordingly. The direction of the arrows should point to the drive drum of the sander.

NOTE: If you are using an old belt, and the arrow markings have worn off, check the direction of travel, see diagram below.

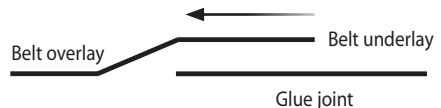

NOTE: Before sliding on the new belt check there is no dust or resin build up on the drums or at the edges of the liner, clean in and around the extraction ports for dust or resin build up, see next page.

CHANGING THE ABRASIVE BELT/DISC

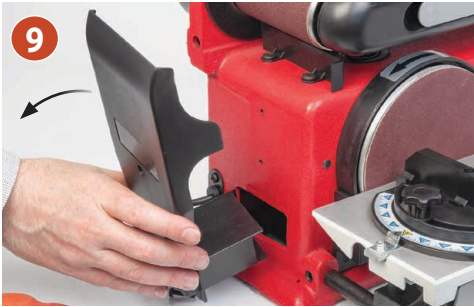
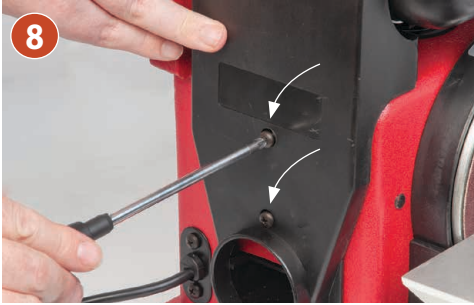

Remove the two screws holding the side extraction panel and check for signs of build up of dust and debris. Clean and replace the panel. Also clean the inside of the linisher.

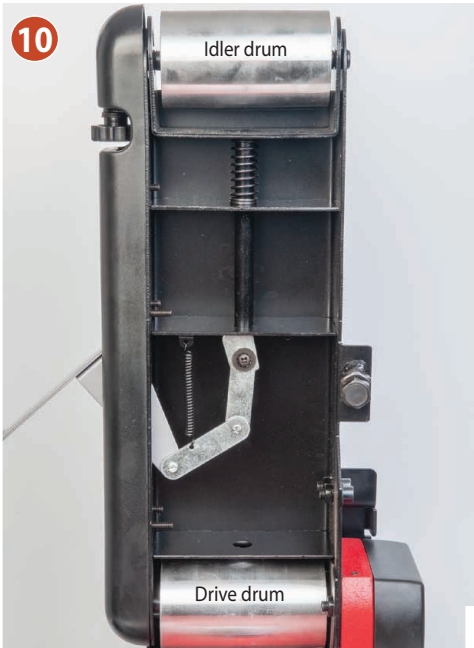

Slide the belt over the drums, making sure the arrows on the belt are pointing down towards the drive drum. Centre the belt and lower the tension lever to re-tension the linisher belt. Replace the rear guard.



CLEAR ALL TOOLS AWAY FROM THE WORK AREA. CONNECT THE SANDER TO THE MAINS SUPPLY!

Give the machine a 'quick' burst check (i.e. quick ON-OFF) to ensure everything is O.K. If everything is satisfactory, continue with operation.



DISCONNECT THE SANDER FROM THE MAINS SUPPLY BEFORE CONTINUING!



WEAR A DUST MASK & EYE PROTECTION WHEN CLEANING YOUR SANDER!

There is very little mechanical maintenance that can be carried out on the machine. Most prudent maintenance is preventative and concerned with keeping the machine clean.

At reasonable intervals, inspect and remove all dust/resin build up using a class 'M' vacuum cleaner.

Remove the worktable (B), side extraction panel/disc extraction plate and clean any dust or resin build up. Inspect the sanding disc for signs of wear and tear and replace if necessary. Re-assemble the sander.

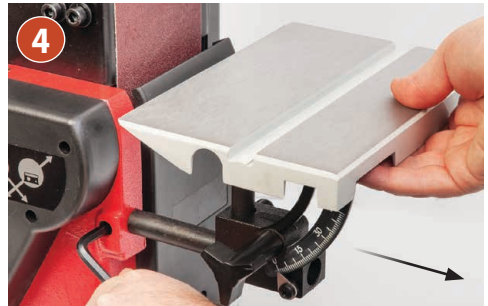
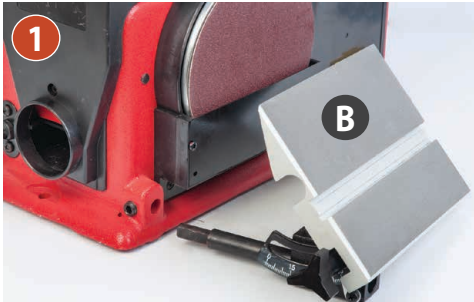

Remove the linisher's guard (E) or worktable (B) and clean any dust or resin build up, inspect the sanding belt for signs of wear and tear and replace if necessary. Re-assemble the sander.

Linisher Drive Belt Tension

If you notice the belt stopping while under load and the disc is still in motion this could mean a sign that the belt is damaged or has become loose. To check, remove the drive belt cover and examine the belt for signs of fraying and missing teeth.



MAINTENANCE

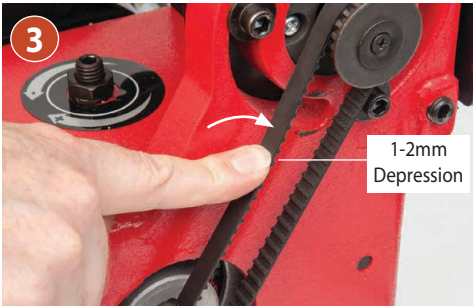

Check the belt tension, if required adjust the drive belt tensioning grub screw and locking nut using the Hex key (C) and spanner, see image (4-5).

Turn the grub screw clockwise (+) to push the motor down or anti-clockwise (-) to decrease the tension.

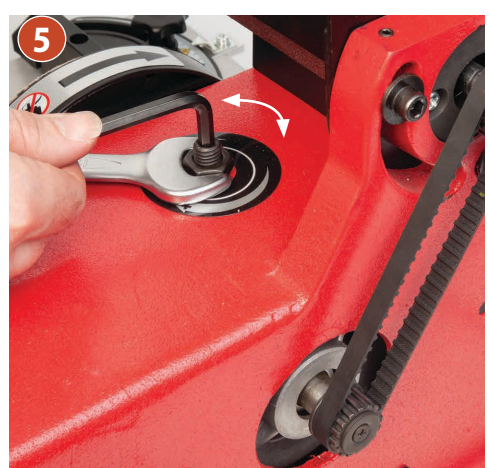
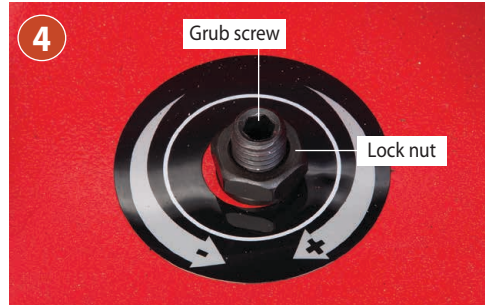

When complete replace the drive belt cover. Clear tools away from work area and connect the sander to the mains supply. Switch on, a gentle sanding action across the face of the belt will check if enough tension has been applied. Disconnect the sander from the mains supply.



DON'T OVER TENSION THE BELT WHICH CAN CAUSE THE MOTOR TO OVERLOAD!

TROUBLE SHOOTING

PROBLEM	POSSIBLE CAUSE	REMEDY
Motor will not run	<ol style="list-style-type: none"> 1. Defective or broken "ON -OFF" switch 2. Defective or damaged switch cord 3. Defective or damaged switch relay 4. Burned out motor 5. Blown fuse 	<ol style="list-style-type: none"> 1-3. Replace all broken or defective parts before using the sander. Contact us on 03332 406406 4. Contact us on 03332 406406 <p>Customer service enquires cs@axminstertools.com</p> <p>Servicing, parts & technical support technicalsupport@axminstertools.com</p>
Machine slows down while sanding	<ol style="list-style-type: none"> 1. Applying too much pressure to workpiece 	<ol style="list-style-type: none"> 1. Apply less pressure to sanding surface
Wood burns while sanding	<ol style="list-style-type: none"> 1. Sanding disc/belt is worn 2. Excessive pressure being applied to workpiece 	<ol style="list-style-type: none"> 1. Replace the disc/belt 2. Reduce pressure being applied to workpiece

EXPLODED DIAGRAMS/LISTS

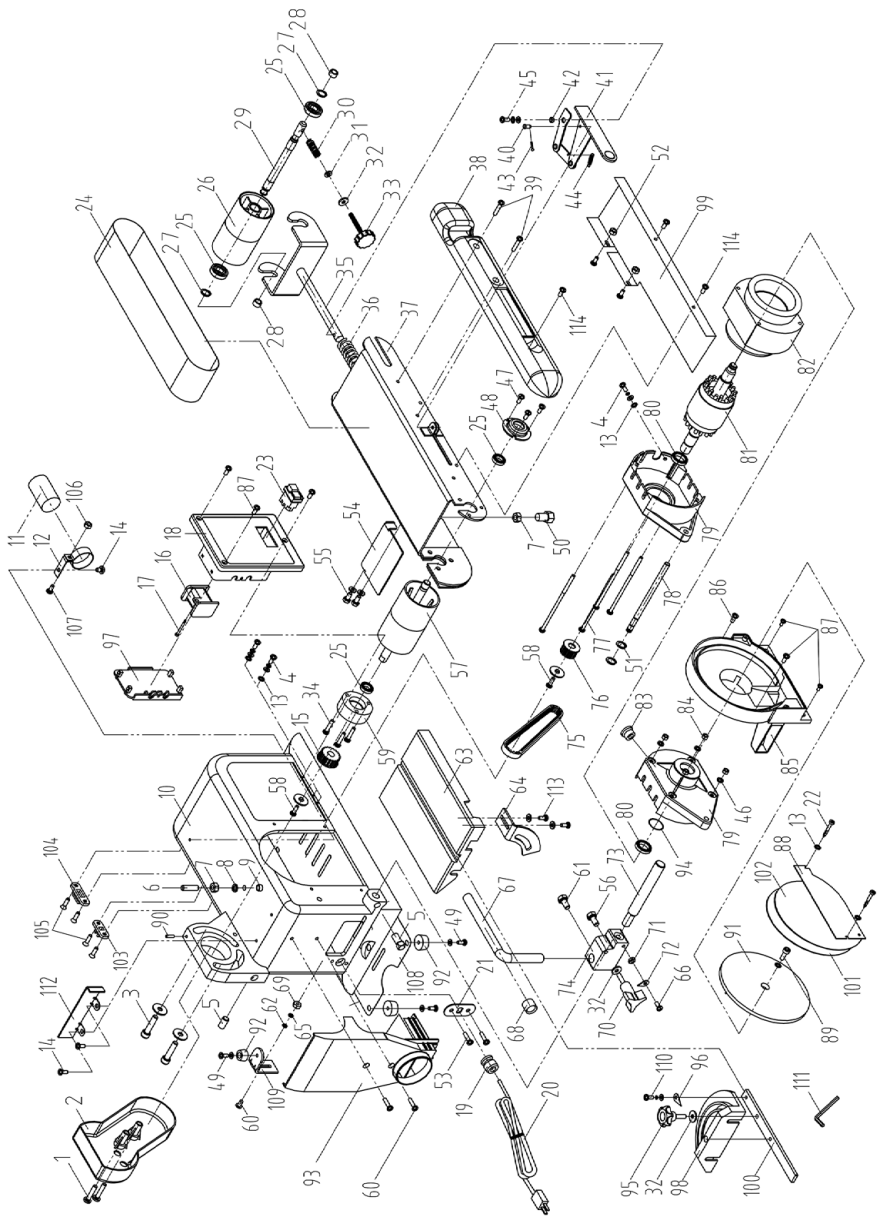

EXPLODED DIAGRAMS/LISTS

No	Specification		Qty
1	Phillips screw	M5 x 35	2
2	Belt guard		1
3	Hex screw	M8 x 35	2
4	Big flat washer	M4 x 8	3
5	Screw	M12 x 10	2
6	Hex screw	M12 x 30	1
7	Hex nut	M12	2
8	Spring washer	φ12	1
9	Sleeve		1
10	Base		1
11	Capacitor	100uF/250V	1
12	Capacitor clamp		1
13	Spring washer	φ4	5
14	Phillips screw	M6 x 8	3
15	Idler pulley		1
16	Relay		1
17	Screw	ST2.9 x 30	1
18	Wire connection box		1
19	Cord clip		1
20	Plug and cord		1
21	Protect plate		1
22	Screw	ST4.2 x 10	2
23	Switch	KJD20-2	1
24	Belt paper		1
25	Bearing	6001	4
26	Idler roller		1
27	Retainer ring	φ12	2
28	Sleeve		2
29	Idler shaft		1
30	Adjustment spring		1
31	Rubber washer		1
32	Flat washer	φ6	3
33	Adjustment knob		1
34	Phillips screw +spring washer	M5 x 25	3

35	Joint lever		1
36	Spring		1
37	Support		1
38	Support cover		1
39	Phillips screw	M5 x 25	2
40	Pin	5 x 10	1
41	Tension knob		1
42	Sleeve		1
43	Pin	1.6 x 10	1
44	Tension pole		1
45	Phillips screw +tooth washer+big flat washer	M5 x 16	1
46	Spring washer	φ6	4
47	Phillips screw	M5X8	3
48	Bearing cap		1
49	Phillips screw+flat washer	M5 x 10	5
50	Hex screw	M12 x 20	1
51	Retainer	φ6	2
52	Retainer washer	M5	2
53	Bolt	M4 x 20	2
54	Limiting plate		1
55	Hex screw+flat washer	M8 x 16	2
56	Hex screw	M8 x 16	1
57	Driving roller		1
58	Phillips screw+lock washer	M5 x 16 left	2
59	Bearing base		1
60	Retainer	M5 x 20	3
61	Phillips screw	M10 x 16	1
62	Flat washer	φ5	1
63	Table		1
64	Mitre gauge		1
65	Spring washer	φ5	1
66	Phillips Screw	M5 x 10	1
67	Support rod		1
68	Table damping set		1

EXPLODED DIAGRAMS/LISTS

69	Hex nut	M5	1
70	Knob		1
71	Hex nut	M6	1
72	Table pointer		1
73	Table support rod		1
74	Connect block		1
75	Belt		1
76	Motor arbor wheel		1
77	Hex bolt	M6 x 122	4
78	Motor rod		1
79	End cap		2
80	Bearing	6203	2
81	Rotor		1
82	Stator		1
83	Cord sleeve		1
84	Hex nut		4
85	Wheel box		1
86	Philips screw		1
87	Philips screw		6
88	Disc cover		1
89	Hex screw	M6 x 16	1
90	Tooth washer	M6 x 16	1
91	Disc		1
92	Rubber foot		5

93	Dust hood		1
94	Wave washer	φ40	1
95	Mitre gauge knob		1
96	Mitre gauge pointer		1
97	Wire connection box cover		1
98	Mitre gauge		1
99	Protect plate		1
100	Mitre gauge rod		1
101	Disc hook		1
102	Disc paper		1
103	Wrench clip		1
104	Mitre gauge clip		1
105	Philips screw		4
106	Hex nut	M4	1
107	Philips screw	M4 x 12	1
108	Base plate		1
109	Motor support		1
110	Philips screw+spring washer+flat washer	M5 x 8	1
111	Hex wrench	M6 x 90 x 32	1
112	Dust plate		1
113	Philips screw+spring washer+flat washer	M5 x 10	2
114	Philips screw	M5 x 16	5

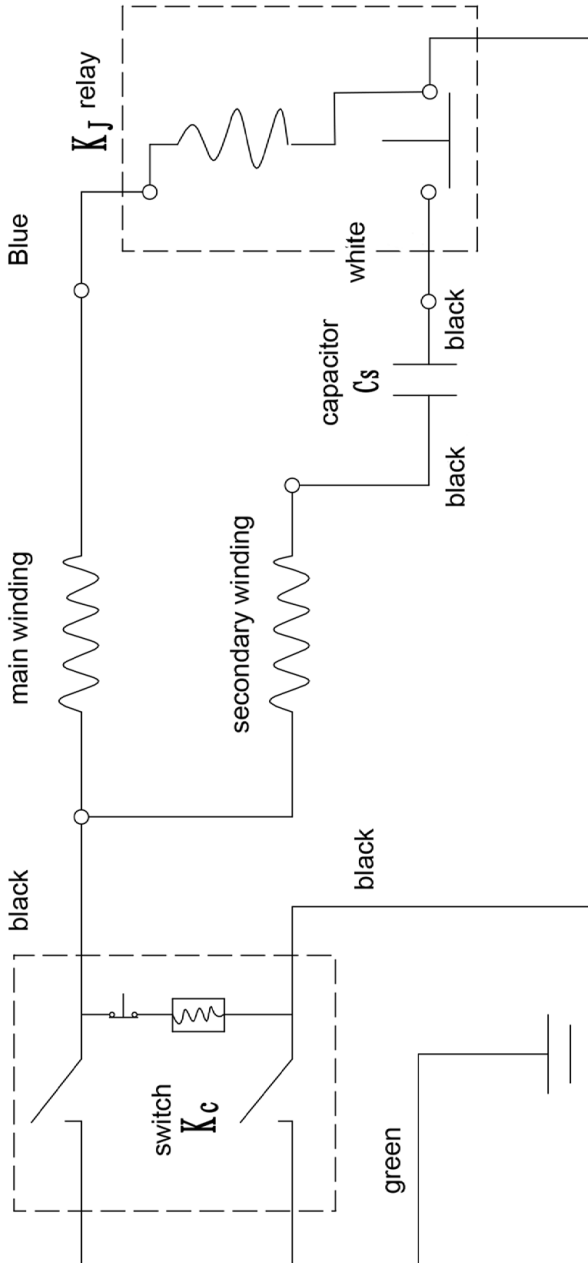

The Axminster guarantee

Buy with confidence from Axminster!

So sure are we of the quality, we cover all parts and labour free of charge for three years!



For more information visit axminstertools.com/3years



The packaging is suitable for recycling.
Please dispose of it in a responsible manner.



EU Countries Only

Do not dispose of electric tools together with household waste material.
By law they must be collected and recycled separately.



Axminster Tools, Axminster Devon EX13 5PH

axminstertools.com